

From lab to fab – Get the testing right

Andy Armutat, Keithley Instruments, Inc.

Moving new products from R&D to Production requires qualification of the testing program. This is much easier if the same equipment is used in both locations, but requires instrumentation with the accuracy, speed, and flexibility to handle both jobs.

From R&D to Production

Electrical testing programs in R&D and production typically have different sets of priorities, even though many of the measurements are the same. In R&D, I-V (current-voltage) data may be plotted in detail and closely examined. In production, fast repeatable I-V measurements are needed for comparison to a few standard values for product acceptance or parts binning decisions.

Correlation between lab and fab I-V test data is needed to ensure that production items hit performance and reliability targets. Duplicating lab instruments in production may seem like a logical answer, but if equipment wasn't selected with that in mind, it may not be practical.

To ensure that measurement equipment performs well in both lab and fab, several criteria should be considered. These include the number of measurement points required on the DUT, sensitivity, repeatability, speed, programmable features, and data handling capabilities.

I-V Data Collection

In both R&D and production, I-V curves are used to characterize devices and materials through DC source-measure testing. These applications may also require calculation of resistance and the derivation of other parameters based on I-V measurements. For example, I-V data can be used to study anomalies, locate maximum or minimum curve slopes, and perform reliability analyses. A typical application is finding a semiconductor diode's reverse bias leakage current

and doing forward and reverse bias voltage sweeps and current measurements to generate its I-V curve.

In the past, these tests were often performed with a dedicated curve tracer¹. Unfortunately, many curve tracers have become obsolete, and those still available range in price from \$15,000 to \$30,000 or more. Most are incompatible with modern computer communication buses, so they require manual setup and operation and may export data only to a floppy disk.

An alternative is a combination of PC connected instruments, such as a voltage or current source and digital multimeter (DMM) or picoammeter. However, this approach requires significant effort to program each instrument, properly connect signal and triggering cables, and resolve timing issues.

Using integrated source-measure instruments reduces equipment cost and the effort required to generate I-V curves. These high precision instruments can act as either a voltage or current source with sweep, pulse, and compliance limit capabilities, and simultaneously measure I and V parameters with high resolution.

Data Correlation Problems

When a new product goes into production, some of the same measurements made in the R&D lab are taken to assure product performance and reliability. Frequently, lack of agreement between lab and fab measurements is a source of great frustration. Lack of correlation

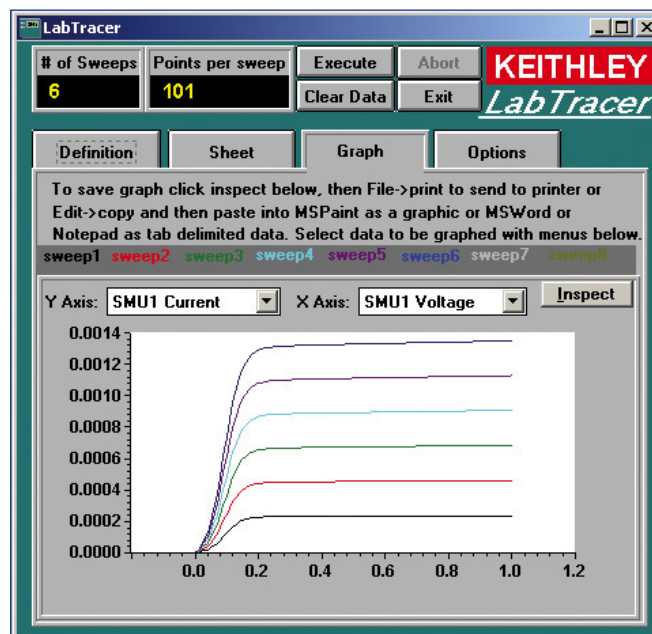

Figure 1. I-V data, such as those used to plot this transistor curve family, are fundamental measurements in many labs and production facilities.

is a function of measurement uncertainty that often arises for several reasons. In general, test instruments account for about half the uncertainty in any given data set. The external test environment, ancillary hardware, and measurement techniques account for the other half. If data sets come from different instruments, then their measurement uncertainty could be greater than that associated with the test environment. On the other hand, a production environment may not be as well controlled as a lab environment, and may create more uncertainty in measurement data from any given instrument.

Therefore, test engineers need to think about the ways uncertainty or change can be introduced into measurements when going from the lab to the fab. They also need to think about the following in both environments:

- Is absolute accuracy important [traceability to national or quantum standards]? This is more likely to be the case in an R&D lab during early stages of development.
- Is it only important that measurements be highly repeatable [i.e., all measurements of a given quantity consistently yield the same result, regardless of the absolute value]? This is often the case in production.
- How long can the measurement take? Generally, there is a tradeoff between measurement speed and accuracy. Speed tends to be paramount in a production environment.

Data sets collected with different measurement techniques, emphasizing different objectives, will probably have different levels of precision² and weak correlation.

Precision can be improved by using the same instrumentation in all test locations and then identifying and minimizing sources of error. The fundamental limitation on resolution (the smallest signal change that can be detected) is determined by the total noise in the measurement circuit. Some of the noise is generated in the DUT, some in the interconnections, and some in the measuring instruments.

Source-Measure Instrument Criteria

SMUs are designed with programmable features that provide cost effective measure-

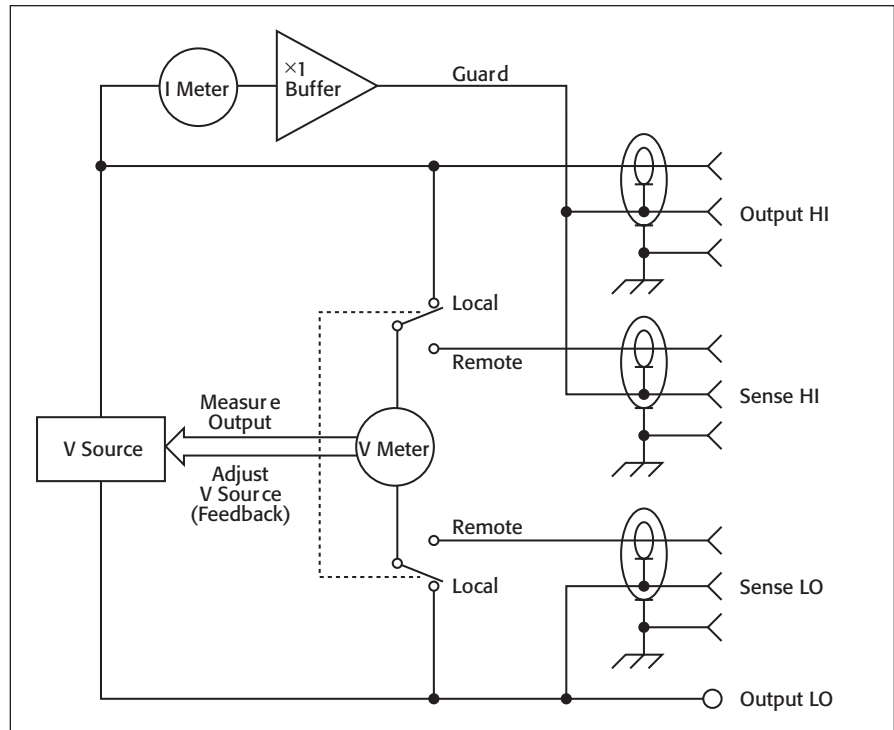

Figure 2. Four-wire (Kelvin) connections using Remote Sense terminals reduce error due to voltage drop in test leads. To reduce leakage current errors, the SMU's guard buffer can be used; it creates a low impedance point in the circuit that is nearly the same potential as the high impedance point to be guarded. The Guard Sense lead detects the potential at that point.

ments in a wide range of applications. They contain bipolar voltage and current sources controlled by a microprocessor; some offer a pulse mode with up to 1kW amplitudes. They can source a series of voltages, measure corresponding currents, and store data in memory until the I-V sweep is completed. Data are then downloaded to the PC controller for processing.

Selecting the right SMU for the application requires evaluation of the following:

- Measurement Sensitivity
- Accuracy/Repeatability
- Speed
- Programmable Hardware/Firmware Features
- Software/Data Handling

Sensitivity, accuracy, repeatability. SMUs can simultaneously apply and measure voltage and current from microvolts and femtoamps up to more than 1000V or 10A. Accuracy and repeatability varies from about 0.025% to 0.10%, depending on the source and measurement ranges selected. If there is significant voltage drop in connecting leads due to high currents, accuracy can be improved with a SMU's four-wire measurement capability (voltage measured or

controlled between 'Sense HI' and 'Sense LO' terminals). Some SMUs have a noise floor as low as 0.4fA p-p, and their guard circuits (Figure 2) can alleviate measurement errors due to stray leakage in cables and fixtures. High sensitivity and accuracy are especially valuable in production testing when a DUT's reverse bias leakage current must be less than a predetermined threshold. By programming the SMU with a compliance limit below the acceptable leakage value, fast 'go/no-go' testing is possible.

Speed/Throughput. SMUs selected for production should have features that speed up testing. These features include a digital I/O interface that lets you link the unit directly to a component handler for some elementary control functions. A hard-wired trigger link between the SMU and other test equipment will reduce external bus traffic. Proper trigger synchronization assures adequate settling time between source application and DUT response measurements, but keeps this time to a minimum for the highest possible throughput.

Programmable Hardware/Firmware Features. Many SMUs are available with program memory (also called a source

memory list) that allows storage of entire test sequences for recall as needed. This further reduces bus traffic, since only one or two commands need to be sent from the PC to the SMU to initiate a sequence. Using the SMU's data buffer allows measurement rates as high as 2000 readings per second. The actual rate depends on the signal integration period, which also is programmable to reduce AC line cycle noise from the test environment. For example, an A/D integration period of only 0.01 PLC (0.01 PLC = 16.7 μ s at 60Hz) will provide measurement resolution of about 4½ digits, and allows maximum measurement speed for produc-

tion test. Longer A/D integration periods maximize measurement resolution for the most accurate device characterization.

Software/Data Handling. SMU manufacturers offer software to increase the versatility of their instruments. For example, Keithley supplies LabTracer software that can control up to four SMUs for curve tracing. This package offers several advantages over traditional curve tracers:

- Flexible control of a diverse family of SMUs to characterize a wide range of devices.
- Each curve tracing channel can have individually customized measurement

parameters.

- The software supports many standard tests, including transistor curve tracing, and characterization of 4-terminal devices.
- Integration of data collection, analysis, and storage without floppy disks; data can be exported directly to a spreadsheet.

Connecting feature-rich SMUs to a PC-controller allows a broad range of measurement objectives to be economically satisfied. Moreover, using SMUs in both R&D and production enables accurate measurements with a high degree of correlation. **KEITHLEY**

1 A curve tracer is essentially an oscilloscope with a built-in DC source for applying voltage or current to the DUT.

2 Precision is a qualitative term. Among a group of I-V measurements, precision is defined by how well the curves match. The degree of mismatch defines the level of uncertainty between the sets of measurements.

Specifications are subject to change without notice.

All Keithley trademarks and trade names are the property of Keithley Instruments, Inc.

All other trademarks and trade names are the property of their respective companies.



Keithley Instruments, Inc.

28775 Aurora Road • Cleveland, Ohio 44139 • 440-248-0400 • Fax: 440-248-6168

1-888-KEITHLEY (534-8453) • www.keithley.com

© Copyright 2004 Keithley Instruments, Inc.
Printed in the U.S.A.

No. 2510
0304